

- Installs easily and quickly
- Retains glass while eliminating rattle
- Eliminates unsightly moulding
- No staples, screws or glue required
- Allows glass to be shipped installed
- Allows glass to "flex" and helps prevent "torquing"
- Makes it much easier to replace broken panes

- To install**
- Route groove
 - Insert glass
 - Insert panel retainer

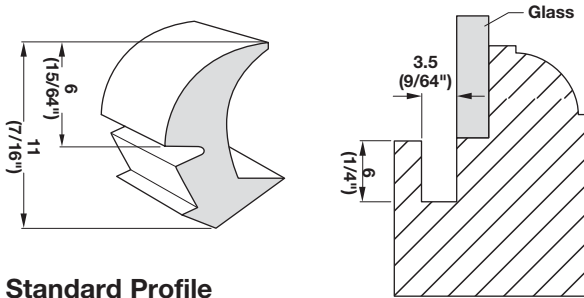
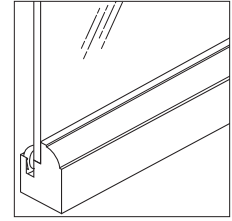

Standard Profile

- For general application

Material: vinyl

| Color | Item No. |
|------------------------|------------|
| transparent | 706.60.411 |
| walnut-dark brown | 706.60.111 |
| fruitwood-medium brown | 706.60.011 |
| off-white | 706.60.711 |

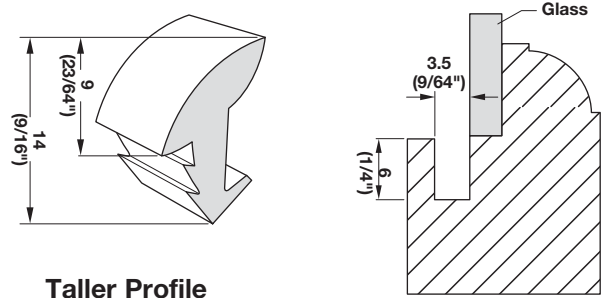

Taller Profile

- For use if glass is cut short or is too thin

Material: vinyl

| Color | Item No. |
|------------------------|------------|
| transparent | 706.62.411 |
| walnut-dark brown | 706.62.111 |
| fruitwood-medium brown | 706.62.011 |
| off-white | 706.62.711 |

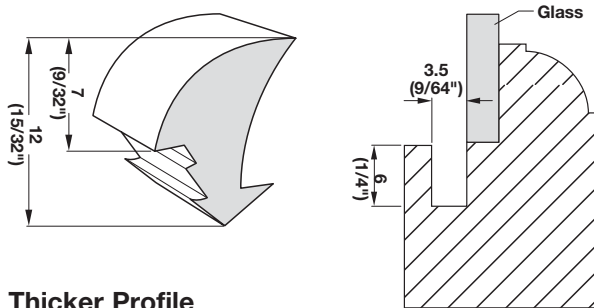

Thicker Profile

- For use if groove is cut too wide

Material: vinyl, transparent

| Length | Item No. |
|-----------------|------------|
| 304.8 m (1000') | 706.61.411 |

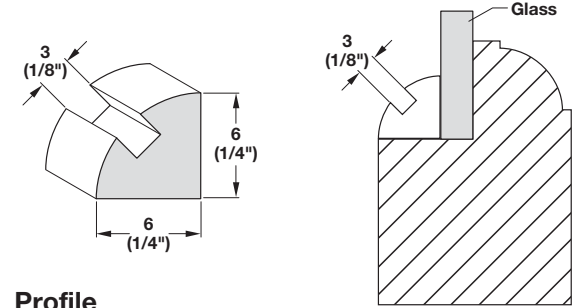

Profile

- Does not require a groove
- Can be stapled in place

Material: vinyl

| Color | Item No. |
|------------------------|------------|
| transparent | 706.63.411 |
| walnut-dark brown | 706.63.111 |
| fruitwood-medium brown | 706.63.011 |
| off-white | 706.63.711 |

Dimensional data not binding. We reserve the right to alter specifications without notice.

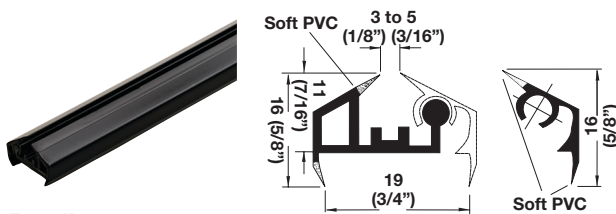

Profile

- 2-part
- Length: 2.5 m (98")

Material: Plastic (hard and soft PVC)

| Color | Item No. |
|-------|------------|
| black | 706.77.300 |
| gray | 706.77.502 |
| white | 706.77.702 |

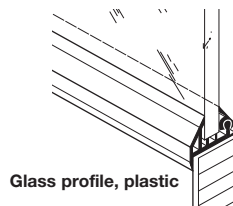

walnut

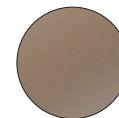

fruitwood



off-white

Dimensions in mm
Inches are approximate