

CPU Holder Fixed Mount

- Securely clamps and holds CPU
- Holds CPU's up and away from shoes, dust, moisture, vacuum cleaners or mops
- Load rating: 25 kg (55 lbs.)
- Height adjustment: 340 - 521 mm (13 3/8" - 20 1/2")

Material: Steel; Color: black epoxy

Width Adjustment	Item No.
140 - 235 (5 1/2" - 9 1/4")	639.72.300
70 - 133 (2 3/4" - 5 1/4")	639.72.320

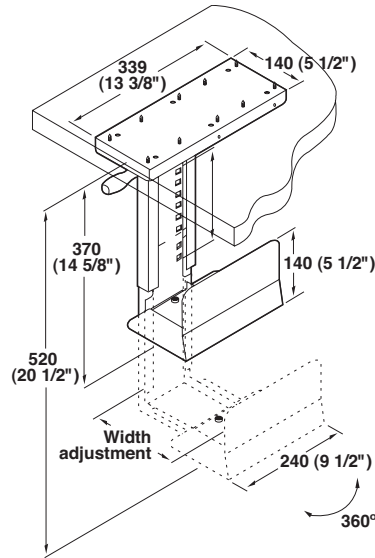

CPU Holder with Swivel and Extension

- 360° swivel provides easy access to connections on the rear of CPU
- Provides 216 mm (8 1/2") of travel for easy access to connections on rear of CPU
- Load rating: 25 kg (55 lbs.)
- Height adjustment: 371 - 521 mm (14 5/8" - 20 1/2")
- Width adjustment: 140 - 235 mm (5 1/2" - 9 1/4")

Material: Steel

Color	Item No.
black epoxy	639.72.310



Dimensional data not binding. We reserve the right to alter specifications without notice.

Dimensions in mm
Inches are approximate