

Full Extension

- Entertainment centers, computer terminals
- Load rating: 60 kg (132 lbs.)
- Durable, long lasting
- Ball cage guided runners
- Smooth and quiet operation

Note

Depending on installation and where load is actually placed, the weight rating can change (leverage effect). For commercial use, please conduct your own test.

4

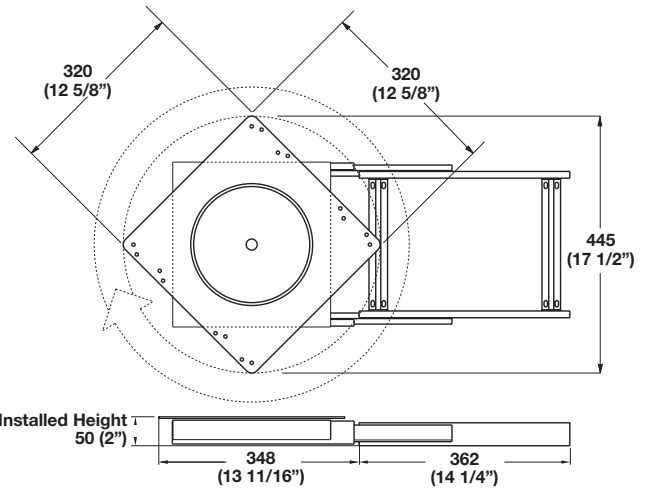
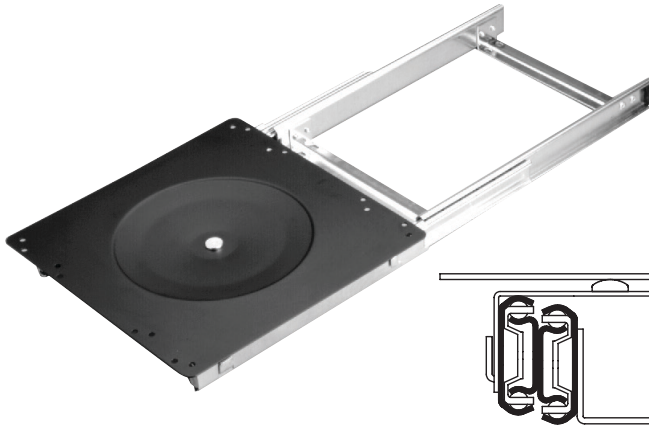

TV Swivel

- Platform designed to carry custom top plate of individual size
- Pivot range 360°

Material: Slides: Steel, galvanized; Platform: Steel

| Color | Item No. |
|-------|------------|
| black | 423.93.300 |

Note

Mounting to shelf (slides) must be done with through-bolt.

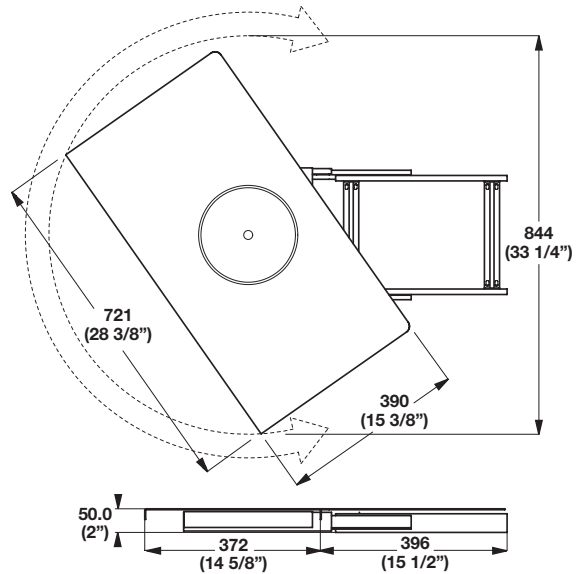
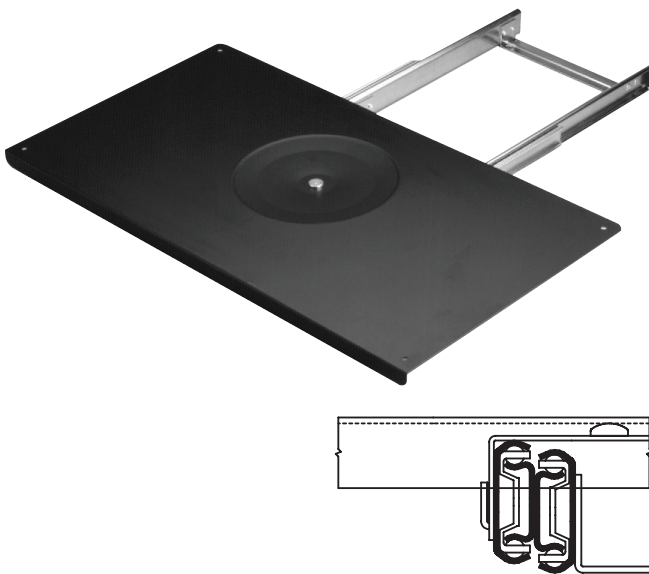

TV Swivel

- Full size platform
- No need to manufacture platform for TV
- Pull-out strip for easy operation
- Pivot range 180°

Material: Slides: Steel, galvanized; Platform: Steel

| Color | Item No. |
|-------|------------|
| black | 423.93.310 |

Dimensional data not binding. We reserve the right to alter specifications without notice.

Dimensions in mm
Inches are approximate