

- Screw-mounted
- The poles are fixed in the case, while the magnet core is adjustable
- Holding power (approximately) 3 – 4 kg
- Catch: fixed
- Strike: floating

Material: Catch: Plastic; Strike: Steel

Color	Item No.
white	246.09.701
brown	246.09.103
black	246.09.309

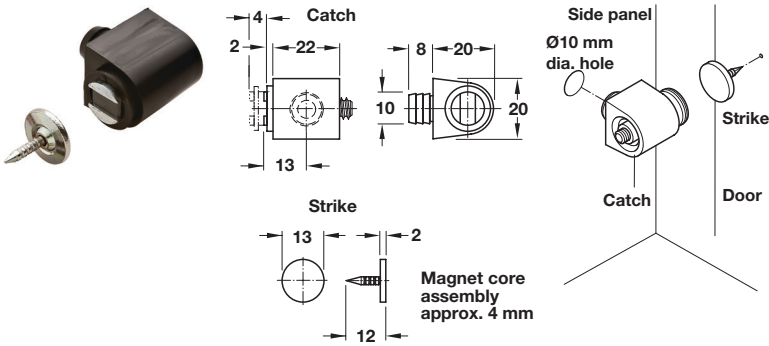

- Press-fit with dowel
- Holding power (approximately) 3 – 4 kg
- Catch: fixed
- Strike: floating

Material: Catch: Plastic; Strike: Steel

Color	Item No.
white	246.08.704
brown	246.08.106
black	246.08.300

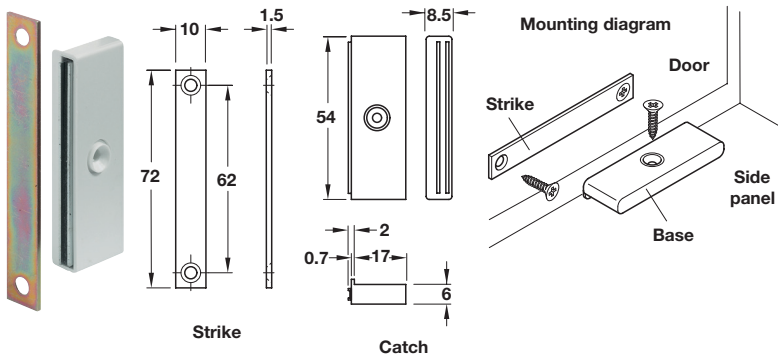

- Screw-mounted
- Holding power (approximately) 5 kg
- Flat (only 6 mm high)
- Adjustable
- Floating poles
- Catch: fixed
- Strike: floating

Material: Catch: Plastic; Strike: Steel

Color	Item No.
white	246.50.708
brown	246.50.100

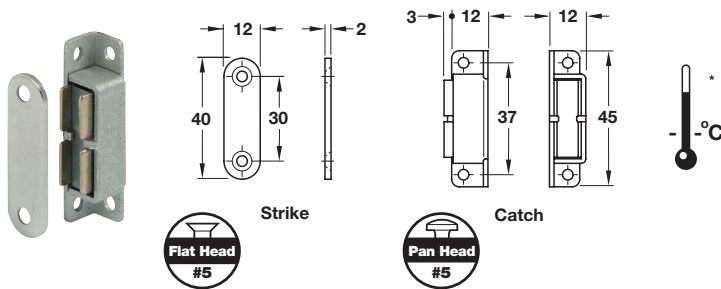

- Screw-mounted
- Metal case provides heat-resistance to 300° C.

Material: Catch: Aluminum; Strike: Steel

Item No.
246.92.000

Note

Holding power is diminished by 1% per 5° C (+). increase in temperature. Cooling restores the magnet's holding power to its original level. No strike is necessary with steel doors or lids.